

EXAMPLE 3.2 In the circuit of Fig. 3.24, a zener diode with $V_{ZK} = 3\text{ V}$ is connected to a resistive circuit that tends to operate the zener in its reverse-biased region. From the circuit diagram alone, it is not evident whether sufficient voltage is developed across the zener to initiate reverse breakdown. Use the graphical technique to determine whether the zener is in its reverse-biased or reverse-breakdown region of operation.

Figure 3.24
 Zener diode connected to a resistive circuit. The reverse-breakdown voltage of the zener is equal to -3 V (i.e., $V_{ZK} = 3\text{ V}$).

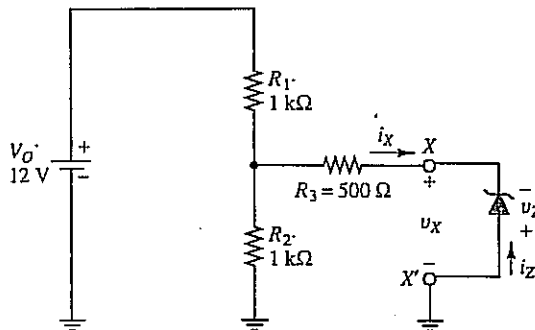

Solution

The analysis parallels that of the *pn* junction diode circuit of Section 3.3.3. The zener, which is the only nonlinear element in the circuit, is temporarily disconnected, and the Thévenin equivalent of the rest of the circuit is found.

- **Find the open-circuit voltage of the resistive circuit with the zener disconnected**

In this case the open-circuit voltage of the resistive circuit consisting of V_O and the three resistors is given by

$$v_{Th} = V_O \frac{R_2}{R_1 + R_2} = 12V \frac{1\text{ k}\Omega}{1\text{ k}\Omega + 1\text{ k}\Omega} = 6V \quad (3.27)$$

Note that R_3 does not appear in the expression for v_{Th} because no current flows through it when the zener is disconnected.

- **Find the Thévenin resistance of the resistive circuit seen by the zener**

The Thévenin equivalent resistance seen by the zener at terminals $X-X'$ can be found by setting the voltage source V_O to zero (short circuit):

$$R_{Th} = R_1 || R_2 + R_3 = 1\text{ k}\Omega || 1\text{ k}\Omega + 500\ \Omega = 1\text{ k}\Omega \quad (3.28)$$

Note that although the presence of R_3 does not affect the open-circuit voltage, it *does* contribute directly to the value of R_{Th} .

- **Find the short-circuit current of the resistive circuit by calculating the ratio of v_{Th} to R_{Th}**

Finally, i_{SC} is found from

$$i_{SC} = \frac{v_{Th}}{R_{Th}} = \frac{6V}{1\text{ k}\Omega} = 6\text{ mA} \quad (3.29)$$

- **Find the operating point of the zener**

In order to find the values of v_Z and i_Z , we need only reconnect the zener to the Thévenin equivalent circuit and utilize the graphical solution technique. In Fig. 3.24, the zener variables v_Z and i_Z are of opposite polarity to those of the Thévenin circuit terminal variables v_X and i_X . If the $v-i$ characteristics of both the zener and the Thévenin circuit are to be plotted on the same set of axes, the $v-i$ curve of one of them must be inverted. This technique was used to analyze the diode circuit of Fig. 3.21 in Section 3.3.3.

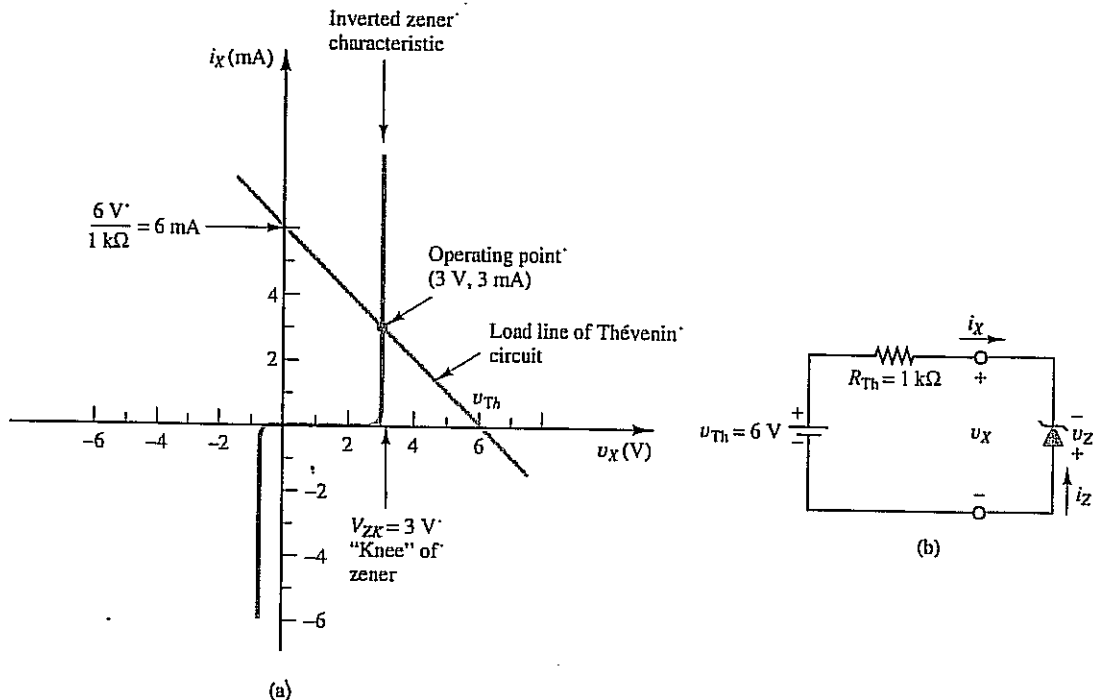

Figure 3.25 Load line of the resistive circuit of Fig. 3.24 superimposed on the inverted v - i characteristic of a zener diode with $V_{ZK} = 3$ V.

The graphical inversion of the zener's v - i characteristic about both the v -axis and i -axis is performed in Fig. 3.25. From these plots, the terminal variables of the Thévenin circuit are seen to be

$$v_x \approx V_{ZK} = 3 \text{ V} \quad (3 \text{ V at the output terminals}) \quad (3.30)$$

$$i_x \approx 3 \text{ mA} \quad (3 \text{ mA flowing out of the Thévenin circuit}) \quad (3.31)$$

The voltage applied to the zener, as defined by the zener's own variable v_z , becomes

$$v_z = -v_x = -V_{ZK} = -3 \text{ V} \quad (3.32)$$

Similarly, the zener current becomes

$$i_z = -i_x = -3 \text{ mA} \quad (-3 \text{ mA flowing in the reverse direction through the zener}) \quad (3.33)$$

For this circuit, the operating point will be located over the "knee" of the zener (i.e., in the reverse-breakdown region) as long as $v_{Th} > V_{ZK}$, where V_{ZK} is a positive number. Conversely, if $v_{Th} < V_{ZK}$, the voltage appearing at the zener's terminals will be of insufficient magnitude to initiate reverse breakdown, and i_z will fall to zero.

- EXERCISE 3.13** Find the voltage across the zener in Fig. 3.24 if V_O is changed from 12 to 16 V. The zener has a V_{ZK} of 3 V. **Answer:** $v_z = -3 \text{ V}$
- 3.14** Find the operating point of the zener in Fig. 3.24 if V_O is changed from 12 to 6 V. The zener has a V_{ZK} of 3 V. **Answer:** $v_z = -3 \text{ V}; i_z = 0$
- 3.15** Find the operating point of the zener in Fig. 3.24 if V_O is changed from 12 to 4 V. The zener has a V_{ZK} of 3 V. **Answer:** $v_z = -2 \text{ V}; i_z = 0$

DESIGN

EXAMPLE 3.3

Using a zener diode and any number of available resistors, design a voltage-reduction circuit that will permit a portable radio normally powered by a standard 9-V “transistor radio” battery to be powered instead from a “12-V” automobile battery. The maximum power that can be dissipated by the zeners that are available is 1 W. The radio requires a maximum of 0.5 W of power at full volume. Note that the voltage from an automobile battery may actually vary over the range 12 to 13.6 V, depending on the battery condition and the total current drawn by the automobile. The value 13.6 V represents the true open-circuit voltage of a six-cell lead-acid battery.

Solution

- Assess the goals of the problem

A circuit is required that can convert a 12-V dc source into a 9-V dc source. Such a circuit must accept 12 V at its input terminals and provide 9 V to the load at its output terminals. Note that 3 V of voltage must be dropped across the voltage-reduction circuit itself if the voltage-reduction goal is to be met. The circuit to be designed must also meet two additional criteria: It must produce its output of 9 V for a variety of input voltages in the range 12 to 13.6 V, and it must maintain this output voltage regardless of the volume setting of the radio (the latter affects the total current drawn by the radio).

- Choose a design strategy

Given the required specifications, a regulating circuit based on a 9-V zener diode forced into its reverse-breakdown region of operation seems a likely candidate. The radio can then be connected directly in parallel with the zener to guarantee that it, too, will see a voltage of precisely 9 V. A maximum of 1 W can be dissipated in the zener under any conditions, including those in which the radio is disconnected. If the zener power limit of 1 W is exceeded, the zener will become excessively hot and may actually melt due to the high heat.

- Design a working version of the circuit

The design process begins with the selection of $V_{ZK} = 9\text{ V}$ for the zener, so that the radio can be connected directly across the zener terminals. Next, the zener must be connected to a resistive circuit designed to maintain its reverse-breakdown condition while safely limiting current flow in the reverse-breakdown direction. The simple circuit of Fig. 3.26, in which the added resistor R_1 transforms the car battery into a Thévenin circuit, can easily perform this task.

Figure 3.26
Zener
voltage-reduction
circuit.

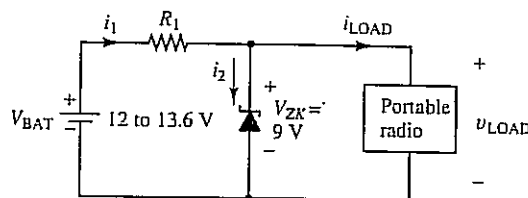

- Choose a value for R_1 , evaluate the design, and revise if necessary

The first objective in choosing a value for R_1 in Fig. 3.26 is to ensure reverse-breakdown operation for the zener under all load conditions, including the case when the radio draws its maximum current. This maximum current can be determined from the radio's power requirement at full volume:

$$\begin{aligned}
 P_{\text{LOAD}} &= v_{\text{LOAD}} i_{\text{LOAD}} \\
 \Rightarrow i_{\text{LOAD-max}} &= \frac{P_{\text{radio-max}}}{V_{\text{LOAD}}} = \frac{0.5\text{ W}}{9\text{ V}} \approx 56\text{ mA}
 \end{aligned}
 \tag{3.34}$$

If the zener is to remain in reverse breakdown, the reverse-breakdown current i_2 in Fig. 3.26 must never fall to zero. A minimum value for i_2 of 1 mA (a nice, round number) is arbitrarily chosen.³ Under maximum load conditions, the current through R_1 must thus equal

$$i_1 = i_2 + i_{\text{LOAD}} = 1 \text{ mA} + 56 \text{ mA} = 57 \text{ mA} \quad (3.35)$$

This current through R_1 must be guaranteed even when V_{BAT} falls to its minimum of 12 V, hence the required maximum value of R_1 becomes

$$R_1 = \frac{V_{\text{BAT}} - V_{\text{LOAD}}}{i_1} = \frac{12 \text{ V} - 9 \text{ V}}{57 \text{ mA}} \approx 52.6 \Omega \quad (3.36)$$

where $v_{\text{LOAD}} = V_{\text{ZK}} = 9 \text{ V}$. The next smallest stock value of $R_1 = 51 \Omega$ is chosen [i_1 acceptably increased to $(12 \text{ V} - 9 \text{ V})/51 \Omega \approx 59 \text{ mA}$]. Note that i_1 will increase to the value

$$i_1 = \frac{V_{\text{BAT}} - V_{\text{ZK}}}{R_1} = \frac{13.6 \text{ V} - 9 \text{ V}}{51 \Omega} \approx 90.2 \text{ mA} \quad (3.37)$$

at the maximum expected battery voltage.

Next we must be certain that the dissipated zener power does not exceed 1 W under worst-case conditions. We note that i_1 will not be affected by the current drawn by the radio. As long as the zener remains in reverse breakdown, i_1 will equal $(V_{\text{BAT}} - V_{\text{ZK}})/R_1$ regardless of the value of i_{LOAD} . In the extreme limit of $i_{\text{LOAD}} = 0$, however (radio disconnected from the voltage-reduction circuit), all of i_1 will flow into the zener as i_2 . Under these conditions, the power dissipated in the zener, defined as $i_2 V_{\text{ZK}}$ under reverse-breakdown conditions, becomes

$$P_Z = i_1 V_{\text{ZK}} = \frac{V_{\text{BAT}} - V_{\text{ZK}}}{R_1} V_{\text{ZK}} \quad (3.38)$$

For the maximum expected car battery voltage of 13.6 V, Eq. (3.38) yields $P_Z = (13.6 \text{ V} - 9 \text{ V})(9 \text{ V})/51 \Omega = 0.81 \text{ W}$. The maximum power limit of 1 W for the zener is not exceeded, even for $V_{\text{BAT}} = 13.6 \text{ V}$.

As a final check, we compute the maximum possible power dissipation in R_1 . The power dissipated in R_1 is given by

$$\begin{aligned} P_{R1} &= V_{R1} i_1 = (V_{\text{BAT}} - V_{\text{ZK}}) \frac{V_{\text{BAT}} - V_{\text{ZK}}}{R_1} \\ &= \frac{(V_{\text{BAT}} - V_{\text{ZK}})^2}{R_1} \end{aligned} \quad (3.39)$$

Evaluating this expression for the worst-case condition $V_{\text{BAT}} = 13.6 \text{ V}$ yields a resistor power dissipation of $(13.6 \text{ V} - 9 \text{ V})^2/51 \Omega = 0.41 \text{ W}$. A resistor with a power rating of at least 0.5 W should be chosen for this application. 

³ For many zeners, V_{ZK} is actually defined as the voltage at which $i_z = -1 \text{ mA}$ in the reverse-breakdown direction.

A voltage regulator accepts “raw” dc voltage as its input, and provides a “pure” dc voltage as its output. A raw, or unregulated, dc voltage is defined as one that fluctuates over time, may contain noise and ripple, but always exceeds in magnitude the desired regulated voltage value. A pure dc voltage is defined as one with near constant magnitude and negligible ripple. The magnitude of the input voltage fed to a regulator need not be constant but must be several percent greater than the desired output voltage at all times. In this way, the regulator can absorb fluctuations in the unregulated input voltage while maintaining a constant output voltage. Although many voltage regulators involve complex integrated circuits, a simple regulator can be made from a zener diode and resistor, as shown in the next example.

DESIGN

EXAMPLE 4.7 Using the zener limiting concept of Example 3.3 in Chapter 3, design a 10 V zener-regulated bridge-rectifier power supply. The supply should be capable of delivering up to 50 mA to its load.

Solution

- Assess the goals of the problem

The power supply must provide dc power at 10 V regardless of the current drawn by the load, up to a maximum load current of 50 mA. The supply must be capable of operating at the extremes of maximum load current or zero load current for an indefinite period of time. As we shall see, this requirement places constraints on the power-handling capabilities of the components in the power-supply circuit.

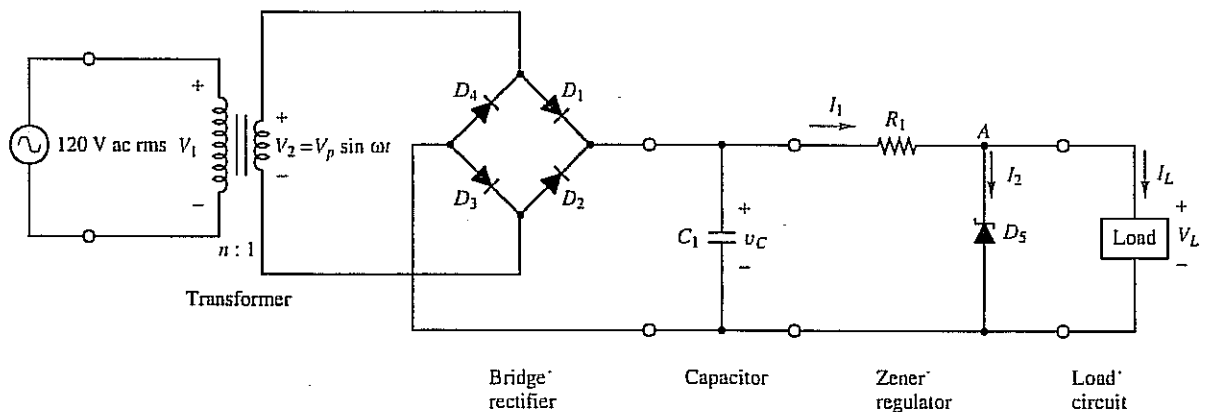
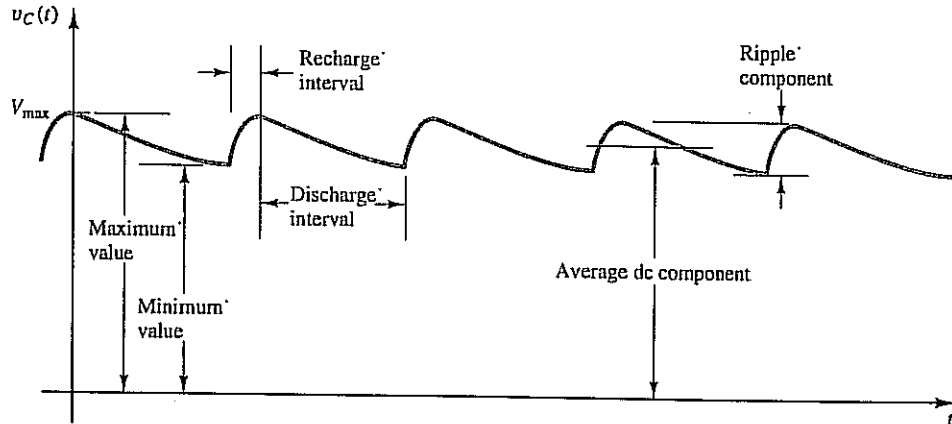

Figure 4.46 Zener-regulated power supply.

- Choose a design strategy

The basic layout of a power supply capable of meeting the design specifications is shown in Fig. 4.46. The circuit consists of a transformer, bridge rectifier, capacitor, and zener regulator. As depicted in Fig. 4.47, the voltage v_C across the capacitor will be a “raw” voltage consisting of a time-varying, ac ripple component superimposed on an average, dc component. The capacitor will be charged to a peak value $V_{\max} = V_p - 2V_f$ after each recharge interval where the bridge-rectifier contributes a total drop of $2V_f$. The role of the zener regulator is to condition this raw dc voltage into a pure dc voltage having a constant value of 10 V and no ripple. As part of the design process, the value of C_1 must be chosen so that the ripple component is small compared to the average dc value of v_C .

Figure 4.47
 “Raw” capacitor voltage v_C versus time. The capacitor is charged to the peak value $V_{\max} = V_p - 2V_f$ after each recharge interval.



- Specify the values of all elements in the circuit

Zener Diode

The first step in the design process is the selection of the zener voltage V_{ZK} . If the zener is to perform its regulation function, it must remain in reverse breakdown at all times. The zener must thus be chosen so that $V_{ZK} = V_L = 10\text{ V}$. This choice of V_{ZK} ignores the slope of the zener's $v-i$ characteristic in the reverse-breakdown region, that is, it assumes $r_z \approx 0$ in the zener's piecewise linear model, so that V_L will be equal to V_{ZK} regardless of the value of current through the zener.

Transformer Turns Ratio

The next step in the design process involves the choice of a turns ratio n for the transformer. This parameter will set the peak secondary voltage V_p , which, in turn, will determine the peak voltage V_{\max} to which the capacitor is charged. Although some leeway exists in the choice of n , it must be chosen such that V_{\max} is greater than V_{ZK} . For this design, we choose (somewhat arbitrarily) a V_{\max} of about 15 V. For a primary ac line voltage of 120 V rms, this value can be obtained by setting the transformer turns ratio to 10, yielding a secondary voltage of 12 V rms, or a peak secondary voltage of $V_p = 12\sqrt{2} = 17\text{ V}$. The peak capacitor voltage at the end of each recharge interval then becomes

$$V_{\max} = V_p - 2V_f = 17\text{ V} - 2(0.6\text{ V}) \approx 15.8\text{ V} \quad (4.42)$$

The latter equation assumes the value $V_f = 0.6\text{ V}$ for each diode in the bridge rectifier. This value for V_f is appropriate for a power-type diode.

Current through the Zener and the Value of R_1

If the zener is to remain in reverse breakdown, the current I_2 into the zener must be nonzero under all load conditions. The choice of the minimum I_2 depends on the specific characteristics of the zener and is somewhat arbitrary. For many zeners, a minimum reverse current of about 1 mA is sufficient to ensure that the diode operates well into its reverse-breakdown region.

In choosing the value of R_1 , an expression is first required for the current I_1 . For the purpose of selecting R_1 , the voltage $v_C(t)$ may be considered an approximate constant equal to V_{\max} . This approximation temporarily neglects the ripple component to v_C , which will be set to a small value later by proper selection of C_1 . If $v_C \approx V_{\max}$, and if the zener remains in reverse breakdown, then I_1 can be expressed as

$$I_1 = \frac{V_{\max} - V_{ZK}}{R_1} \quad (4.43)$$

Given the previously selected values of V_{\max} and V_{ZK} , the resistor R_1 must be chosen so that I_1 is set to an appropriate value. Applying KCL to node A yields $I_1 = I_2 + I_L$. Because I_L might

be as large as 50 mA, I_1 thus must be set to at least 51 mA if the power supply is to meet its design specifications. This choice will ensure that under full-load conditions ($I_L = 50$ mA), a minimum of 1 mA will flow into the zener as reverse-breakdown current. Note that I_1 , as given by Eq. (4.43), will be constant regardless of load current as long as the zener remains in reverse breakdown. If the load should draw less than the maximum of 50 mA, the remainder of I_1 will flow into the zener as additional reverse-breakdown current.

Applying Eq. (4.43) with $V_{\max} = 15.8$ V, $V_{ZK} = 10$ V, and a minimum desired I_1 of 51 mA results in a tentative, maximum value for R_1 :

$$R_1 \leq \frac{V_{\max} - V_{ZK}}{I_{1\min}} = \frac{15.8 \text{ V} - 10 \text{ V}}{51 \text{ mA}} \approx 114 \Omega \quad (4.44)$$

Because most discrete resistors are available only in certain "stock" values with 5% tolerance, the next *smallest* stock value of 100 Ω should be chosen, yielding an I_1 of 58 mA. Note that the actual resistance of a 5% 100- Ω "stock" resistor can vary between the approximate values 105 and 95 Ω . Hence I_1 may actually vary over the range 55 to 61 mA. The next highest stock resistor of 120 Ω , with extreme $\pm 5\%$ tolerance limits of 126 and 114 Ω , will yield I_1 values between 46 and 51 mA, respectively. Although this choice of resistor value *could* yield the desired I_1 at one extreme end of its range, insufficient I_1 will flow over most of its tolerance range, hence this choice for R_1 is not a good one.

Capacitor C_1

The last component to be selected is the capacitor C_1 . Its value must be large enough such that the ripple component of v_C is truly negligible compared to the dc average value of v_C . At the very least, the ripple component of v_C must be small enough such that the zener remains in reverse breakdown even at the end of the capacitor discharge interval.

The ripple component of the capacitor voltage can be estimated by assuming I_1 to be constant even when v_C contains a ripple component. For constant I_1 , the discharge of v_C will be governed by the equation

$$\frac{dv_C}{dt} = \frac{-I_1}{C_1} \quad (4.45)$$

The duration of the capacitor discharge interval will be approximately equal to one-half of the sinusoidal period T ; hence the magnitude of v_{ripple} can be estimated as

$$|v_{\text{ripple}}| \approx \left| \frac{dv_C}{dt} \frac{T}{2} \right| = \frac{I_1 T}{C_1 2} \quad (4.46)$$

If the zener is to remain in reverse breakdown even when the capacitor has discharged to its minimum voltage, the ripple must be small enough so that

$$V_{\max} - |v_{\text{ripple}}| > V_{ZK} \quad (4.47)$$

Given a V_{\max} of 15.8 V, Eq. (4.47) becomes

$$|v_{\text{ripple}}| < V_{\max} - V_{ZK} = 15.8 \text{ V} - 10 \text{ V} = 5.8 \text{ V} \quad (4.48)$$

From Eq. (4.46), the capacitance C_1 must therefore be chosen so that

$$C_1 \gg \frac{I_1 T}{|v_{\text{ripple}}| 2} = \frac{58 \text{ mA} (16.7 \text{ ms})}{5.8 \text{ V} (2)} \approx 83 \mu\text{F} \quad (4.49)$$

In this equation, the value $I_1 = 58$ mA has been used. This current value corresponds to that obtained with $R_1 = 100 \Omega$, rather than to the minimum required value of 51 mA.

The selection of C_1 must provide an ample margin of safety to ensure that the inequality (4.49) is adequately met and to compensate for any tolerance variations in R_1 . A good rule of thumb that is standard practice in electronics is to make C_1 at least five times the minimum required value. This choice is obviously arbitrary—a larger value of C_1 will lead to an even smaller ripple component to v_C —but its use by engineers is based on experience as well as trial and error. In this case, the value $C_1 = 470 \mu\text{F}$ will yield a capacitor ripple component of about 1 V.

• **Evaluate the design and revise if necessary**

As a final step in the design process, the power dissipated in the resistor and in the zener must be examined. Under worst-case conditions ($I_L = 0$, and R_1 equal to its lower tolerance limit of 95Ω), the current flowing into the zener will be equal to 61 mA, leading to a dissipated zener power of

$$P_Z = V_Z I_Z = (61 \text{ mA})(10 \text{ V}) = 0.61 \text{ W} \quad (4.50)$$

Choosing a 1-W zener will leave an adequate safety margin.

As long as the zener remains in reverse breakdown, the power dissipated in the resistor will be constant, regardless of the load current. This power should be computed using an R_1 on the low end of the tolerance limit. With V_{max} and V_L assumed constant, the smaller value of R_1 will yield the largest resistor power dissipation. For the value $R_1 = 95 \Omega$, the power dissipated in the resistor becomes

$$P_R = (V_{\text{max}} - V_{ZK})^2 / R_1 = (5.8 \text{ V})^2 / 95 \Omega = 0.35 \text{ W} \quad (4.51)$$

A $\frac{1}{2}$ -W power rating should suffice for R_1 .

Note that the component values selected in this design example do not represent a unique solution to the problem. Many other values of n , R_1 , and C_1 will still yield a power-supply design that meets the required specifications. 

- EXERCISE 4.34** Compute the ripple component of v_C in the power-supply circuit of Example 4.7 if C_1 is changed from 470 to 1000 μF . **Answer:** about 480 mV
- 4.35** Show that the extreme limits of I_1 in the circuit of Example 4.7 become 46 and 51 mA, respectively, if a 120- Ω , 5% tolerance resistor is chosen for R_1 .
- 4.36** Find the required minimum value of capacitance for $|v_{\text{ripple}}| < 5.8$ V in the circuit of Example 4.7 if the ac supply has a frequency of 50 Hz, rather than 60 Hz. **Answer:** 100 μF
- 4.37** Find the maximum value of R_1 in the circuit of Example 4.7 if the maximum load current is 100 mA, rather than 50 mA. The approximate capacitor voltage V_{max} is to remain at 15.8 V. **Answer:** 57 Ω
- 4.38** Consider the power-supply design of Example 4.7. How small can V_{max} become at full load current ($I_L = 50$ mA) before regulation ceases with $I_2 = 0$? Assume that $R_1 = 100 \Omega$. **Answer:** 15 V
- 4.39** Consider the power-supply design of Example 4.7. How small can V_{max} become at zero load current before the zener ceases to regulate the output voltage? Assume that $R_1 = 100 \Omega$ and that a minimum of 1 mA must flow in the zener for adequate regulation. **Answer:** 10.1 V